

COMPLETIAMO
LA TUA
LINEA

RICERCHIAMO
FUNZIONALITÀ
IN OGNI
FORMA



Azienda Company



QUALITÀ VERSATILITÀ RICERCA INNOVAZIONE PERSONALIZZAZIONE FUNZIONALITÀ TECNOLOGIA

La Giesse Technology è un marchio della G.S. Plast fondata nel 1988 su iniziativa dell'attuale titolare sig. Stefano Gasparetti. Egli vanta una esperienza trentennale nel campo della progettazione e realizzazione di articoli tecnici in resine termoplastiche e fusioni in leghe di zinco. In pochi anni l'originalità delle soluzioni tecniche abbinata alla ricerca di materiali innovativi ed un design curato nei particolari ha consentito all'azienda di qualificarsi tra le imprese leader produttrici di piedini per mobili ed accessori per il settore arredamento. La Giesse progetta e fabbrica completamente all'interno del proprio stabilimento tutti i componenti dei propri articoli, essendo anche dotata di una efficientissima officina meccanica qualificata per la realizzazione di stampi in acciaio per alte produzioni, sia per materie plastiche che per metalli. Il personale altamente qualificato della Giesse, la tecnologia all'avanguardia utilizzata e la rigidità dei controlli di qualità effettuata sui materiali e sui prodotti finiti rappresentano la necessaria garanzia per la clientela più esigente ed attenta ad ogni particolare.

Giesse Technology is a brand of G.S. Plast was founded in 1988 on initiative of the owner, Mr. Stefano Gasparetti, who has a 30 years experience in developing and realizing technical items in thermoplastic resin and fusions in zinc alloys. In few years the originality of the technical solutions, together with the search of innovative materials and a special care of the design, allowed the company to qualify among the leading producers of feet and accessories for furniture.

Giesse projects and produces in its own factory all parts of its items, thanks to the efficient workshop qualified for the realization of steely moulds for high level production both of plastic materials and of metals. The high qualified staff of Giesse, the leading edge technology used and the rigorous quality check on materials and end products represent the fundamental guarantee for a customer hard to please, focusing on every detail.



TECNOLOGIA TECHNOLOGY

L'officina vanta oltre dieci macchinari per lo stampaggio della plastica e della zama e l'ufficio progettazione si avvale della moderna stampante 3D per la prototipazione. Le presse per la plastica hanno una potenza che spazia da un minimo di 7 ad un massimo di 140 tonnellate utilizzando varie tipologie di materiali dai più comuni ai più tecnici.

Our production department boasts more than ten plastic and zamak molding machineries and uses an innovative 3D printer for prototyping new R&D projects. The plastic molding machines can apply a pressure range from 7 to 140 tons, using both common or technical materials.



QUALITÀ QUALITY

Tutta la produzione della Giesse è perfettamente in linea con i più alti standard qualitativi richiesti dal mercato. La rigorosità dei controlli sui materiali, test funzionali e la scrupolosità delle procedure applicate nel processo produttivo rispondono contantemente alle aspettative di tutti i clienti.

Giesse's production ensures the higher quality standards required by the market. The strict controls of all the materials used, the functional tests and a deep attention on all the applied procedures of productive processes, will result in meeting the highest quality expectations of any clients.



INNOVAZIONE MADE IN ITALY INNOVATION MADE IN ITALY

La Giesse Technology raccoglie le esigenze più diverse dei Clienti, creando proposte con valore aggiunto sempre originale, grazie anche alla collaborazione con Designer e Architetti di consolidata esperienza garantisce la continua innovazione stilistica del prodotto made in Italy. Una continua sperimentazione, supportata da investimenti mirati nella ricerca e sviluppo, rendono l'Azienda sempre più competitiva sul mercato e proiettata verso il futuro.

Giesse technology is able to manage the most exigent and different customer's requests. Cooperating with well know Industrial Designers and Architects it's able to create original valuable proposals with a special eye design innovation, always Made in Italy. A continuous research, supported by aimed investments in R&D, makes the company increasingly competitive in the market and projected to the future



PERSONALIZZAZIONE CUSTOM-MADE

Un grande pregio della Giesse è l'eccellenza: la possibilità di gestire in autonomia le proprie produzioni, spesso con progetti ad hoc, a testimonianza della fiducia dei clienti verso chi presta assoluta attenzione e cura ad ogni minimo particolare.

L'evoluzione dell'azienda è stata continua, ben presto l'esperienza si è messa a disposizione di progetti nuovi, con materiali innovativi, sotto la costante accuratezza tecnica e un design sempre molto ricercato, grazie ad un efficiente ufficio progettazione e sviluppo, in grado di ideare soluzioni personalizzate. Questo ha permesso alla Giesse di ricavarsi uno spazio vantando di impotanti collaborazioni con nomi prestigiosi italiani ed internazionali e studi di architettura.

A huge Giesse's value is versatility, like the possibility to manage independently its productions, often with customized projects, as a proof of customer's trust obtained by an extremely care and attention in every small detail.

Since born, the company never stopped to grow, always researching new innovative projects to realize, using new materials, new designs with a constant care for technical details.

This gave to Giesse the space to establish important business relationships with prestigious Italian and International companies

Reggimensole/Reggivetro/Bloccaporta
Brackets/Glass brackets/Door-block



Su richiesta: Finitura bianco opaco RAL 9003
Imballo disponibile anche in blister o in scatola
singolo componibile.

Upon request: Matt white finish RAL 9003
Packaging available in blister pack or single
components in boxes.



CORPO AZ75 – CORPO

Portata 25Kg / coppia

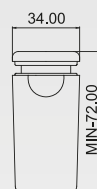
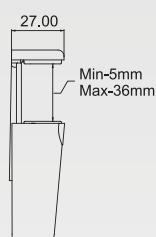

COD.	CONF.	FINITURA
AZ75/000001	2 pz scatola	Alluminio
AZ75/000002	2 pz scatola	Cromo lucido
AZ75/000003	2 pz scatola	Ottone lucido
AZ75/000004	2 pz scatola	Ottone invecchiato
AZ75/000006	2 pz scatola	Marrone
AZ75/000007	2 pz scatola	Piombo

REGGIMENSOLA AZ75.A – L75

Portata 25Kg / coppia

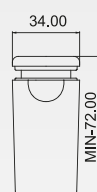
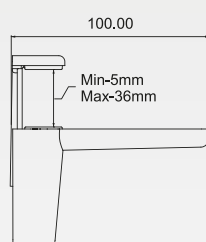

COD.	CONF.	FINITURA
AZ75.A/000001	2 pz scatola	Alluminio
AZ75.A/000002	2 pz scatola	Cromo lucido
AZ75.A/000003	2 pz scatola	Ottone lucido
AZ75.A/000004	2 pz scatola	Ottone invecchiato
AZ75.A/000006	2 pz scatola	Marrone
AZ75.A/000007	2 pz scatola	Piombo

REGGIMENSOLA AZ75.B – L130

Portata 25Kg / coppia

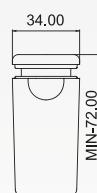
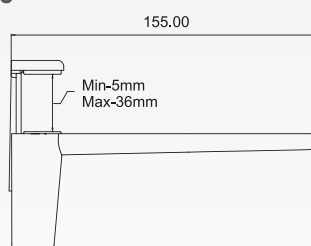

COD.	CONF.	FINITURA
AZ75.B/000001	2 pz scatola	Alluminio
AZ75.B/000002	2 pz scatola	Cromo lucido
AZ75.B/000003	2 pz scatola	Ottone lucido
AZ75.B/000004	2 pz scatola	Ottone invecchiato
AZ75.B/000006	2 pz scatola	Marrone
AZ75.B/000007	2 pz scatola	Piombo

REGGIMENSOLA AZ75.C – CON APPENDINO

Portata 30Kg / coppia

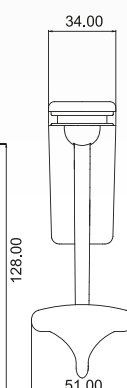
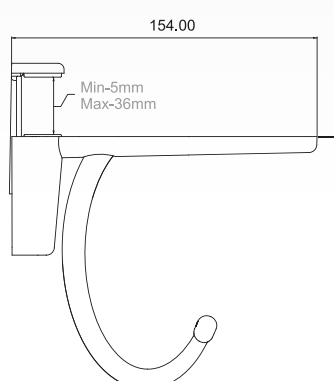

COD.	CONF.	FINITURA
AZ75.C/000001	2 pz scatola	Alluminio
AZ75.C/000002	2 pz scatola	Cromo lucido
AZ75.C/000003	2 pz scatola	Ottone lucido
AZ75.C/000004	2 pz scatola	Ottone invecchiato
AZ75.C/000006	2 pz scatola	Marrone
AZ75.C/000007	2 pz scatola	Piombo

Coppia reggimensole / Reggilavabo
 Profilo in alluminio 25x25
 Su richiesta: Finitura bianco opaco RAL 9003

Couple Brackets / Sink brackets
25x25 Aluminium profile
Upon request: Matt white finish RAL 9003

COPPIA REGGILAVABO CON REGOLABILI

Portata 85Kg / coppia

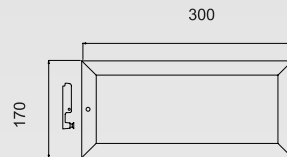

COD.	FINITURA
40.005	Anodizzato
40.006	Brill lucido

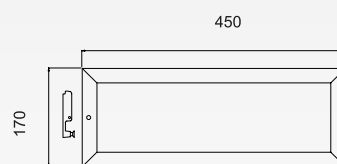

COD.	FINITURA
40.002	Anodizzato
40.004	Brill lucido

Reggimensola in zama *Zinc alloy bracket*

DUNA GRANDE

Portata 35Kg

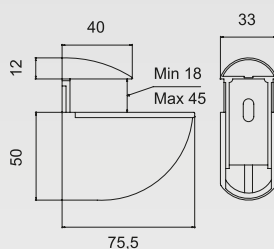

COD.	CONF.	FINITURA
AZ79/000001	2pz scat.	Alluminio
AZ79/000003	2pz blist.	Alluminio
AZ79/000014	2pz scat.	Bianco
AZ79/000016	2pz blist.	Bianco
AZ79/000002	2pz scat.	Cromo lucido
AZ79/000013	2pz blist.	Cromo lucido
AZ79/000005	2pz scat.	Ottone lucido
AZ79/000009	2pz blist.	Ottone lucido
AZ79/000004	2pz scat.	Nikel satinato
AZ79/000010	2pz blist.	Nikel satinato
AZ79/000011	2pz scat.	Ottone antico
AZ79/000012	2pz blist.	Ottone antico

DUNA MEDIA

Portata 25Kg

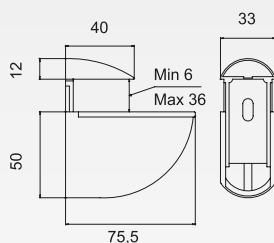

COD.	CONF.	FINITURA
AZ76/000007	2pz scat.	Alluminio
AZ76/000017	2pz blist.	Alluminio
AZ76/000011	2pz scat.	Bianco
AZ76/000008	2pz blist.	Bianco
AZ76/000006	2pz scat.	Cromo lucido
AZ76/000018	2pz blist.	Cromo lucido
AZ76/000012	2pz scat.	Ottone lucido
AZ76/000020	2pz blist.	Ottone lucido
AZ76/000015	2pz scat.	Nikel satinato
AZ76/000019	2pz blist.	Nikel satinato
AZ76/000014	2pz scat.	Ottone antico
AZ76/000027	2pz blist.	Ottone antico

DUNA PICCOLA

Portata 18Kg

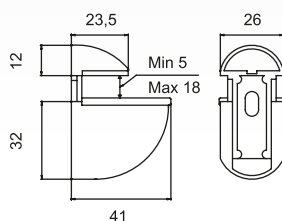

COD.	CONF.	FINITURA
AZ92/000013	2pz blist.	Alluminio
AZ92/000007	8pz scat.	Alluminio
AZ92/000021	2pz blist.	Bianco
AZ92/000010	8pz scat.	Bianco
AZ92/000001	2pz blist.	Cromo lucido
AZ92/000012	8pz scat.	Cromo lucido
AZ92/000014	2pz blist.	Ottone lucido
AZ92/000003	8pz scat.	Ottone lucido
AZ92/000005	2pz blist.	Nikel satinato
AZ92/000006	8pz scat.	Nikel satinato
AZ92/000022	2pz blist.	Ottone antico
AZ92/000004	8pz scat.	Ottone antico

In zama
Su richiesta: Finitura bianco opaco RAL 9003

Zinc alloy
Upon request: Matt white finish RAL 9003

DISTANZIALE AZ139

Foratura vetro 19 mm
Spessore di serraggio da 6-10 mm

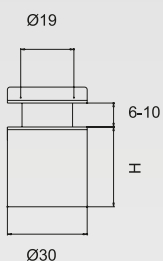

COD.	H	FINITURA
AZ139-15/000002	15	Cromo lucido
AZ139-15/000003	15	Nikel satinato
AZ139-15/000004	15	Ottone lucido
AZ139-15/000005	15	Cromo perla
AZ139-30/000002	30	Cromo lucido
AZ139-30/000003	30	Nikel satinato
AZ139-30/000004	30	Ottone lucido
AZ139-30/000005	30	Cromo perla

DISTANZIALE AZ140

Foratura vetro 19 mm
Spessore di serraggio da 6-10 mm

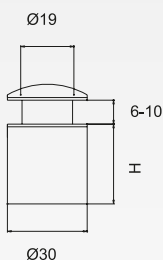

COD.	H	FINITURA
AZ140-15/000002	15	Cromo lucido
AZ140-15/000003	15	Nikel satinato
AZ140-15/000006	15	Ottone lucido
AZ140-15/000005	15	Cromo perla
AZ140-30/000002	30	Cromo lucido
AZ140-30/000003	30	Nikel satinato
AZ140-30/000006	30	Ottone lucido
AZ140-30/000005	30	Cromo perla

DISTANZIALE AZ 147

Foratura vetro 10 mm
Spessore di serraggio da 4-10 mm

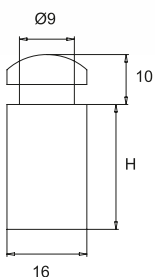

COD.	H	FINITURA
AZ147-15/000001	15	Cromo lucido
AZ147-15/000002	15	Nikel satinato
AZ147-15/000003	15	Ottone lucido
AZ147-15/000004	15	Cromo perla
AZ147-25/000001	25	Cromo lucido
AZ147-25/000002	25	Nikel satinato
AZ147-25/000003	25	Ottone lucido
AZ147-25/000004	25	Cromo perla

In zama

Zinc alloy

REGGIVETRO AZ80

Altezza da 4 a 10 mm

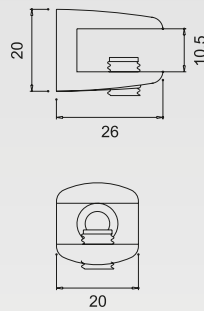

COD.	FINITURA
AZ80/000006	Alluminio
AZ80/000005	Cromo lucido
AZ80/000009	Ottone lucido
AZ80/000008	Nikel satinato
AZ80/000010	Ottone invecchiato
AZ80/000012	Bianco

REGGIVETRO AZ81

Altezza da 4 a 10 mm

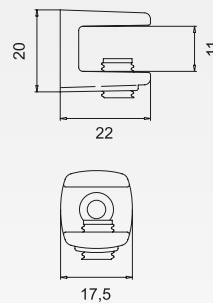

COD.	FINITURA
AZ81/000001	Alluminio
AZ81/000002	Cromo lucido
AZ81/000003	Ottone lucido
AZ81/000004	Nikel satinato
AZ81/000005	Ottone invecchiato
AZ81/000008	Bianco

REGGIVETRO AZ82

Altezza da 4 a 10 mm

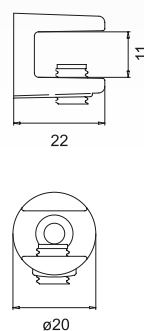

COD.	FINITURA
AZ82/000001	Alluminio
AZ82/000002	Cromo lucido
AZ82/000003	Ottone lucido
AZ82/000004	Nikel satinato
AZ82/000005	Ottone invecchiato
AZ82/000008	Bianco

In zama

Zinc alloy

REGGIVETRO AZ99

Altezza da 16 in zama

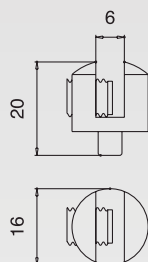

COD.	FINITURA
AZ99/000001	Cromo lucido
AZ99/000003	Alluminio
AZ99/000004	Ottone lucido
AZ99/000005	Nikel satinato

REGGIVETRO AZ142

Altezza da 6 a 10 mm

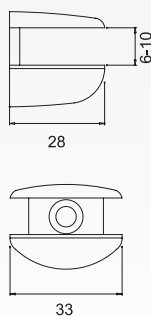

COD.	FINITURA
AZ142/000001	Alluminio
AZ142/000002	Cromo lucido
AZ142/000003	Nikel satinato
AZ142/000004	Ottone lucido
AZ142/000006	Bianco opaco

In zama - resina termoplastica
Su richiesta: Finitura bianco opaco RAL 9003

Thermoplastic resin - Zinc alloy
Upon request: Matt white finish RAL 9003

BLOCCAPORTA AZ138

In zama

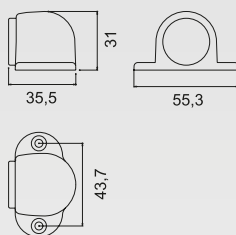

COD.	FINITURA	CONF.
AZ138/000002	Cromo lucido	12pz scat.
AZ138/000004	Nikel satinato	12pz scat.
AZ138/000001	Alluminio	12pz scat.
AZ138/000006	Ottone invecchiato	12pz scat.
AZ138/000009	Bronzato	12pz scat.
AZ138/000005	Ottone lucido	12pz scat.

BLOCCAPORTA AP123

Resina termoplastica

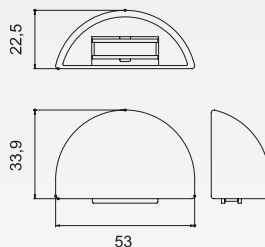
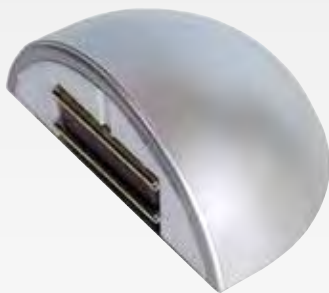

COD.	FINITURA	CONF.
AP123/000001	Nero	1pz blist.
AP123/000002	Legno ciliegio	1pz blist.
AP123/000003	Legno noce	1pz blist.
AP123/000004	Marrone	1pz blist.
AP123/000005	Cromo lucido	1pz blist.
AP123/000006	Oro lucido	1pz blist.
AP123/000007	Alluminio	1pz blist.
AP123/000008	Bianco	1pz blist.

BLOCCAPORTA AP124

Resina termoplastica

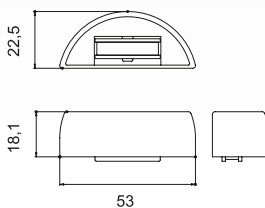

COD.	FINITURA	CONF.
AP124/000003	Cromo lucido	2pz blist.
AP124/000004	Alluminio	2pz blist.
AP124/000005	Bianco	2pz blist.
AP124/000006	Oro lucido	2pz blist.
AP124/000007	Legno noce	2pz blist.
AP124/000017	Marrone	2pz blist.
AP124/000001	Legno ciliegio	2pz blist.

Supporti bloccaporta

Door block support

AZ

In zama

Zinc alloy

Su richiesta: Finitura bianco opaco RAL 9003

Upon request: Matt white finish RAL 9003

REGGIMENSOLA AZ145

Attacco a parete angolare per AZ138

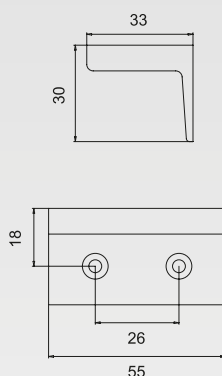

COD.	FINITURA	CONF.
AZ145/000002	Cromo lucido	24pz scat.
AZ145/000004	Nikel satinato	24pz scat.
AZ145/000001	Alluminio	24pz scat.
AZ145/000003	Ottone lucido	24pz scat.
AZ145/000006	Bronzato	24pz scat.

REGGIMENSOLA AZ146 - H 15 mm

Supporto per AZ 138

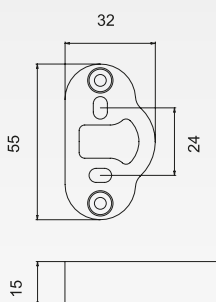

COD.	FINITURA	CONF.
AZ146/000008	Cromo lucido	24pz scat.
AZ146/000004	Nikel satinato	24pz scat.
AZ146/000001	Alluminio	24pz scat.
AZ146/000002	Ottone lucido	24pz scat.
AZ146/000012	Bronzato	24pz scat.

REGGIMENSOLA AZ146 - H 30 mm

Supporto per AZ 138

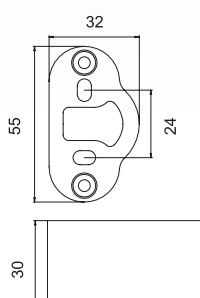

COD.	FINITURA	CONF.
AZ146/000010	Cromo lucido	24pz scat.
AZ146/000003	Nikel satinato	24pz scat.
AZ146/000009	Alluminio	24pz scat.
AZ146/000006	Ottone lucido	24pz scat.
AZ146/000007	Bronzato	24pz scat.

Totem Espositivo

Expo Corner



Contatti

Contacts



Giesse Technology è un marchio della GS PLAST
Giesse Technology is a brand of GS PLAST

G.S. Plast
di Gasparetti Stefano

Via Sbrozzola, 7
60021 Camerano (An) Italy
Tel. 071 959252 Fax 071 959261

Sito web: www.giesse-technology.it
E-mail: info@giesse-technology.it
giesse-technology@pec.it

Skype: [giesse-technology](https://www.skype.com/people/giesse-technology)



www.giesse-technology.it